

STARGATE

X-SCALE, PROCESSOR PLATFORM

- ▼ 400MHz, Intel PXA255 Processor
- ▼ Low Power Consumption
<500 mA
- ▼ Embedded Linux BSP Package,
Source Code Shipped with Kit
- ▼ Small, 3.5" x 2.5" Form Factor
- ▼ PCMCIA and Compact Flash
Connector
- ▼ 51-pin Expansion Connector
for MICA2 Motes and other
Peripherals
- ▼ Ethernet, Serial, JTAG, USB
Connectors via 51-pin
Daughter Card Interface
- ▼ Li-Ion Battery Option

Applications

- ▼ Single-Board Embedded Linux
Computer
- ▼ Sensor Network Gateway
- ▼ Custom 802.11a/b Gateway
- ▼ Robotics Controller Card
- ▼ Distributed Computing Platform

STARGATE

The Stargate is a high-performance processing platform designed for sensor, signal processing, control, and wireless sensor networking applications. The Stargate is based on Intel's Xscale® processor, and it is the same processor found in today's most powerful handheld computers including the Compaq IPAQ® and the Dell Axim®.

The Stargate processor board is the result of the combined design efforts of several different Ubiquitous Computing research groups within Intel. The completed design is licensed to Crossbow Technology for commercial production. The Stargate processor board is preloaded with a Linux distribution and basic drivers. A variety of useful applications and development tools is also provided.



The Stargate processor module is compatible with Crossbow's MICA2 family of wireless sensor networking products (using the embedded TinyOS platform) and the public domain software from Intel's Open-Source Robotics initiative. The Stargate processor module is also an ideal solution for standalone Linux-based Single Board Computer (SBC) applications.

With its strong communications capability and Crossbow's ongoing commitment to its open-source architecture, the Stargate platform offers tremendous flexibility. The SPB400CB Processor Board has both Compact Flash and PCMCIA connectors as well as optional installable headers for 2 serial ports and an I2C port. The SDC400CA Daughter Card supports a variety of additional interfaces, including:

- RS-232 Serial
- 10/100 Ethernet
- USB Host
- JTAG

Finally, the standard MICA2 Mote connector on the SPB400CB Processor Board provides support for synchronous serial port, (SSP), UART, and other GPIO connections.

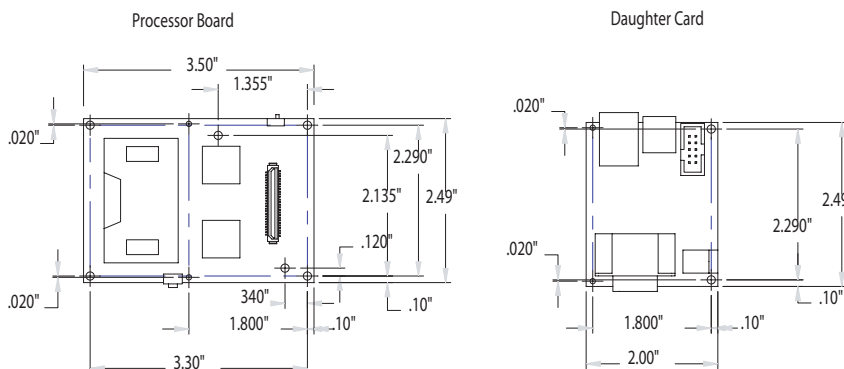

Specifications	Remarks
STARGATE Processor Board	
Intel PXA255, Xscale®	400 MHz, RISC Processor
Intel SA1111, StrongARM®	Multiple I/O Companion Chip
Memory	
64 MB SDRAM	
32 MB FLASH	Linux Software < 10 MBytes
Communications	
PCMCIA Slot	Type II
Compact Flash Slot	Type II
51-pin MICA2/GPIO	UART, SSP via MICA2 Connector
Optional I2C Port	Installable Header
Optional Serial Port (2)	Installable Header
General	
Li-Ion Battery Option	
Watch Dog Timer (WDT)	Configurable up to 60 seconds
Battery Gas Gauge	
LED and User Application Switch	
Power Switch	
STARGATE Daughter Card	
Communications	
10 Base-T Ethernet Port	RJ-45 Connector
RS-232 Serial Port	DB-9 Connector
JTAG Debug Port	
USB Host Port	Version 1.1
General	
A/C Power Adaptor	5-6 VDC, 1 Amp
Reset Button	
Real-Time Clock	
Physical	
Processor Board	
(in) 3.50 x 2.49 x 0.73	Excluding Daughter Card
(cm) 9.53 x 6.33 x 1.86	Excluding Daughter Card
Weight (oz) 1.68	
(g) 47.47	
Daughter Card	
(in) 2.49 x 2.00 x 0.60	
(cm) 6.33 x 5.08 x 1.52	
Weight (oz) 1.42	
(g) 40.16	
Environmental	
0 to +70 (°C)	Operating Temperature

Specifications subject to change without notice

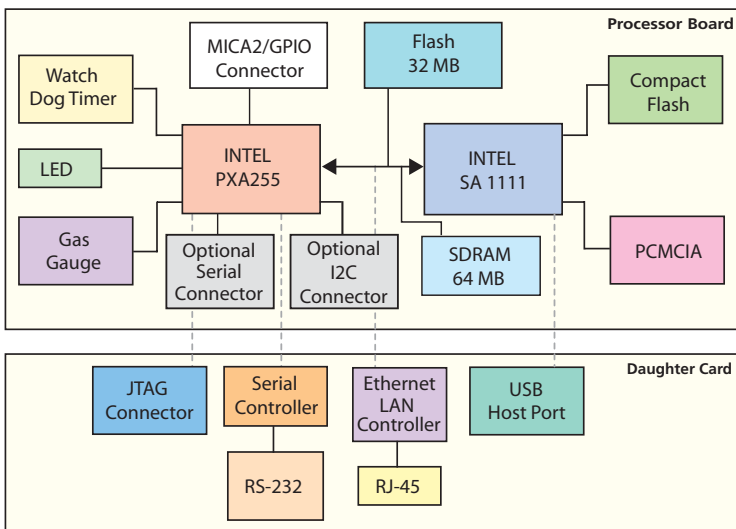

Stargate Block Diagram

▼ Processor Board - Top

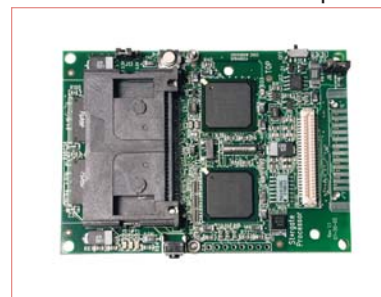

▼ Processor Board - Bottom



▼ Daughter Card



Stargate Basic Kit Contents

- Stargate Processor Board
- Stargate Daughter Card
- Power Supply
- Null Modem Cable
- CD-ROM

Advanced Kit Contents

- All Basic Kit Contents
- Logitech QuickCam® Pro 4000
- Ambicom Wave2Net® 802.11b CF Card

CD-ROM Contents

- Linux - Kernel & Driver Sources
- GNU Cross Platform Dev. Tools
- Bootloader with Source Code
- Flash Programming Utility
- Shareware & Test Applications
- Developer's Guide - PDF Format

Ordering Information

Model	Description
SP-KIT400CA	Stargate Basic Developer's Kit
SP-KIT420CB	Stargate Advanced Developer's Kit including USB webcam and WIFI
SPB400CB	Stargate Processor Board
SDC400CA	Stargate Daughter Card - JTAG, 10/100 Ethernet, Serial, USB Host